

ProLiant BL p-Class GbE2 Interconnect Switch Compatibility with Cisco-based Networks

white paper



Abstract.....	2
Introduction.....	2
Terminology.....	3
Same technology, different form factor.....	3
VLANs and VLAN tagging.....	4
Spanning tree.....	4
Multi-link trunking.....	5
Security.....	6
Management.....	6
Port mirroring.....	7
Multicast traffic.....	7
Network time.....	7
Conclusion.....	7
For more information.....	8

Abstract

This white paper describes the interoperability of the ProLiant BL p-Class GbE2 Interconnect Switch with Cisco-based Ethernet networks consisting of Catalyst switches. This document is not intended to be a guide for deploying a GbE2 Interconnect Switch within a Cisco-based network. For this information, see the [Deploying the ProLiant BL p-Class GbE2 Interconnect Switch into a Cisco-based Network](#) white paper¹.

The intended audience for this paper includes engineers and system administrators familiar with the HP ProLiant BL p-Class system. For readers not familiar with the HP ProLiant BL p-Class system, more information is available at <http://h18004.www1.hp.com/products/servers/platforms/index-bl.html>. For general information about the p-Class GbE2 Interconnect Switch options, see [ProLiant BL p-Class GbE2 Interconnect Switch Overview](#) white paper².

Introduction

The ProLiant BL p-Class system consists of ProLiant BL server blades, the 6U (10.5 inch) BL p-Class server blade enclosure, network and power infrastructure components, and software that enables adaptive computing optimized for rapid deployment.

The p-Class server blade enclosure holds the server blades and two interconnects. Each server contains multiple network interface controllers (NICs). The enclosure has a signal backplane that routes the server blade NIC signals to the interconnects in a redundant, highly available architecture. HP offers a family of interconnect options for a choice of how the Ethernet, as well as Fibre Channel, signals exit the server blade enclosure. Available interconnects include two patch panel pass-through kits and two integrated Ethernet switch kits (interconnect switch kits). The two patch panel options allow all Ethernet network signals to pass through to third-party LAN devices, thus giving customers flexibility in choosing their own switches. The interconnect switch kits provide up to 32-to-1 Ethernet cable consolidation reducing the time to deploy and manage ProLiant BL p-Class systems.

The ProLiant BL GbE2 Interconnect Switch is the newest interconnect option available for p-Class systems. The ProLiant BL GbE2 Interconnect Switch is an industry-standard, 24-port all Gigabit Ethernet switch intended for:

- Applications that require up to 1000 megabits per second (Mb/s) NIC consolidation
- Connectivity to copper-based 10/100/1000T or fiber-based 1000SX Ethernet networks
- Fibre Channel storage signal pass-through for the ProLiant BL20p and BL30p series servers
- Advanced network feature support (including planned future options for layer 3 through 7)
- Future planned upgradeability for 10 Gigabit Ethernet bandwidth connectivity to the network

For more information about the GbE2 Interconnect Switch, see the [ProLiant BL p-Class GbE2 Interconnect Switch Overview](#) white paper.¹

In a typical application, the GbE2 Interconnect Switches acts as a redundant access switch layer that is in turn connected to the core network often consisting of Catalyst switches from Cisco Systems (Cisco). This white paper identifies the ProLiant BL p-Class GbE2 Interconnect Switch interoperability within a Cisco-based Catalyst switch Ethernet network. Topics discussed include VLANs, spanning tree, multi-link trunking, security, management, and more.

¹ Available at <http://h18004.www1.hp.com/products/servers/proliant-bl/p-class/bl-p-interconnect-switch2.html>.

² Available at <http://h18004.www1.hp.com/products/servers/proliant-bl/p-class/bl-p-interconnect-switch2.html>.

Terminology

Terminology used in this document that differs between Cisco Catalyst switches and the GbE2 Interconnect Switch is identified in Table 1.

Table 1. Network terminology cross reference

HP ProLiant GbE2 Interconnect Switch	Cisco Catalyst switches
VLAN tagging, 802.1Q tagging	trunking, VLAN or 802.1q encapsulation
port VLAN identification (PVID)	VLAN identification (VLANID)
link aggregation, multi-link trunking (MLT)	EtherChannel, channeling
spanning tree protocol group (STG)	spanning tree instance
IEEE 802.1s, multiple spanning tree	per VLAN spanning tree (PVST), PVST+
port mirroring	SPAN, RSPAN

Same technology, different form factor

In a typical tiered server network configuration designed with redundancy, two or more network interface controllers (NIC) are used per server. The Ethernet signals from these NICs are routed to two separate access switches that are in turn connected to the core network. One or more “crosslink” connections are commonly made between the access switches for added availability. The access switch “downlink” ports are used to collect NIC signals from the servers for aggregation to the network backbone via one or more “uplink” ports. The GbE2 Interconnect Switch and p-Class blade architecture uses the same technology to provide this function, but in a different form factor (Figure 1).

Figure 1. Typical redundant network configuration

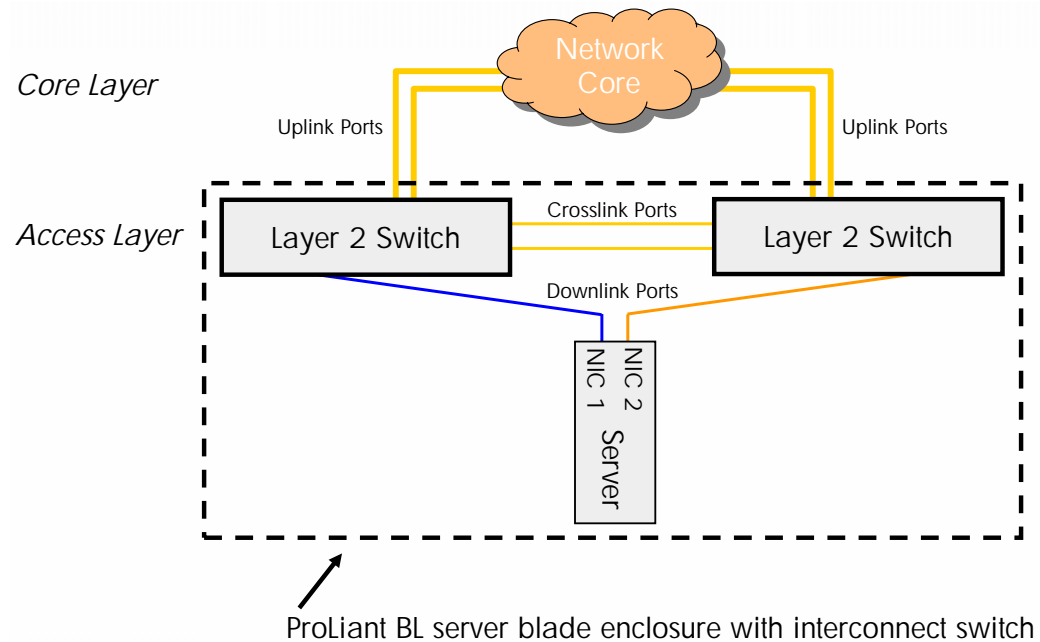

The access switches and connections have been moved inside the BL p-Class server blade enclosure. The GbE2 Interconnect Switches become the access switch layer that is in turn connected to the core switch layer. The same network technology is used and the tiered network configuration remains unchanged. Because the interconnect switch is an industry-standard managed layer 2 switch, it is compatible with other industry-standard switches including Catalyst switches from Cisco.

The remainder of this paper discusses the GbE2 Interconnect Switch interoperability with Cisco Catalyst switches in the areas of.

- VLANs and VLAN tagging (VLAN trunking)
- spanning tree
- multi-link trunking (EtherChannel)
- security
- management
- port mirroring (SPAN, RSPAN)
- multicast traffic

VLANs and VLAN tagging

Each GbE2 Interconnect Switch provides 255 port-based IEEE 802.1Q virtual local area networks (VLANs) compatible with Catalyst switches that support this industry standard. Both the Catalyst switches and GbE2 Interconnect Switches utilize VLAN1 as the default VLAN. This permits immediate out-of-the-box passing of Ethernet traffic.

To create VLANs across the network, the GbE2 Interconnect Switch supports IEEE 802.3ac VLAN Ethernet frame extensions for 801.2Q tagging³. Each switch port may be individually configured as tagged or untagged. Therefore, GbE2 Interconnect Switch VLANs may span Cisco switches that support the 802.1Q tagging methodology. Although Cisco typically refers to 802.1Q VLAN tagging as VLAN trunking or dot1q trunking, the technologies are the same and, therefore, completely interoperable. The key is to ensure that ports on both ends of the tagged link (or dot1Q trunk) are assigned to same VLANs.

The Cisco proprietary VLAN tagging Inter Switch Link (ISL) is an alternative method that predates the IEEE 801.1Q tagging standard. The GbE2 Interconnect Switch does not support ISL. Cisco recommends that "*...new implementations follow the IEEE 802.1q standard and older networks gradually migrate from ISL*" to allow multi-vendor interoperability, greater field exposure, greater third party support, and, to a lesser degree, 802.1Q's lower encapsulation overhead.⁴

Lastly, the GbE2 Interconnect Switch cannot be used as a participating node with Cisco's VLAN Trunk Protocol (VTP). However, the interconnect switch may be used as a VTP transparent mode to forward VTP information.

Spanning tree

Spanning tree is enabled by default on the GbE2 Interconnect Switch to ensure that any existing network layer 2 loops are blocked. The GbE2 Interconnect Switch meets the IEEE 802.1D standard and is compatible with Cisco switches that are 802.1D compliant. The bridge priorities, port costs, and port priorities may be manually assigned on the GbE2 Interconnect Switch. This allows the core or other Catalyst switches to be the root bridge.

³ The IEEE 802.3 standards have been merged into a single standard defined as IEEE 802.3-2002. IEEE 802.3-2002, section 3.5 (Elements of the Tagged MAC Frame) now contains the specifications previously defined in IEEE 802.3ac.

⁴ *Best Practices for Catalyst 4000, 5000, and 6000 Series Switch Configuration and Management*, Cisco Systems, Document 13414, October 1, 2003; available at http://www.cisco.com/en/US/products/hw/switches/ps663/products_tech_note09186a0080094713.shtml.

The GbE2 Interconnect Switch further provides interoperability with Cisco's Per-VLAN Spanning Tree Plus (PVST+) 801.Q tagging proprietary protocol via the use of spanning tree groups (STG). In the GbE2 implementation, an administrator creates an STG and then assigns a VLAN to it. This differs from the Cisco implementation where an administrator creates a VLAN, and then a spanning tree instance (i.e. STG) is automatically created and assigned to the VLAN.

The PVST+ interoperability feature on the GbE2 Interconnect Switch includes the following:

- Tagged ports may belong to more than one STG, but untagged ports can belong to only one STG.
- When a tagged port belongs to more than one STG, egress BPDUs are tagged to identify their STG membership.
- An untagged port cannot span multiple STGs.
- Sixteen STGs operating simultaneously are supported per GbE2 Interconnect Switch.
- The default STG 1 can hold multiple VLANs; all other STGs (groups 2–16) can hold one VLAN.

The GbE2 Interconnect Switch provides two methods to interoperate with PVST+:

1. All GbE2 Interconnect Switch VLANs configured on the ports connected to the Catalyst switches may be added to the default STG (STG 1).
2. A unique GbE2 Interconnect Switch STG may be created for each of the configured VLANs connecting to the Catalyst switches.

For rapid spanning tree convergence, many Catalyst switches support Cisco's proprietary features PortFast, UplinkFast, and BackboneFast, as well as the industry-standard IEEE 802.1w. The 802.1w extension is an enhancement to the original 802.1D standard. As noted by Cisco, 802.1w provides similar convergence time improvements to the Cisco methods, but 802.1w provides the added benefit of interoperability between vendors. Support for the 802.1w standard is planned for a future GbE2 Interconnect Switch software release. In the meantime, the GbE2 Interconnect Switch does allow the disabling of spanning tree on a per switch or port basis. This capability is ideal for networks designed without loops or individual switch ports connected to server blades or other devices where a loop does not exist.

Multi-link trunking

Multi-link trunking (MLT), also known as link aggregation, port trunking, and Cisco EtherChannel, combines multiple physical switch ports into a single logical port called a trunk. The bandwidth of the trunk is the aggregate of the bandwidth of the individual links.

The industry standard for multi-link trunking is IEEE 802.3ad⁵. Cisco has developed a similar multi-link trunking method known as EtherChannel. The GbE2 Interconnect Switch supports IEEE 802.3ad (802.3-2002) without LACP⁶ that is compatible with EtherChannel. The GbE2 Interconnect interoperates with both Fast EtherChannel, providing link aggregation for Fast Ethernet (100MB) ports, and Gigabit EtherChannel, which aggregates Gigabit Ethernet (1000MB) links. The GbE2 Interconnect Switch supports twelve trunks per switch. Each trunk may contain two to six ports providing a 12-Gbps aggregate throughput full duplex.

An algorithm automatically applies load balancing to the ports in the trunk. A port failure within the group causes the network traffic to be directed to the remaining ports. Load balancing is maintained whenever a link in a trunk is lost or returned to service. This provides flexible and scalable bandwidth with resiliency and load sharing across the links between the GbE2 Interconnect Switch and Cisco

⁵ The IEEE 802.3 standards have been merged into a single standard defined as IEEE 802.3-2002. IEEE 802.3-2002, section 43 (Link Aggregation) defines the standards specified in IEEE 802.3ad.

⁶ Link aggregation control protocol (LACP) is an enhancement over EtherChannel and other static multi-link trunking methods. LACP dynamically learns about the link status and takes decisions on which links to use for and load balancing and fallback in case of link failure. As a result, IEEE 802.3ad with LACP is often called dynamic trunking.

devices. To determine the load balancing decisions, varying methods are used. Catalyst switches may use the packet's source MAC (SMAC) address, destination MAC (DMAC) address, source IP (SIP) address, destination IP (DIP) address, or a combination of these methods. The GbE2 Interconnect Switch uses a combination of SMAC and DMAC addresses to make the load balancing decision.

Security

The GbE2 Interconnect Switch supports remote authentication dial-in user service (RADIUS) client, communicating to the network RADIUS server to authenticate and authorize a remote administrator using the protocol definitions specified in RFC 2138 and 2866. The GbE2 Interconnect Switch will integrate into an existing Cisco network that uses this industry-standard authentication and authorization protocol. As is performed on the Catalyst switches, the RADIUS configuration on the GbE2 Interconnect Switch requires the user to specify the IP address of the RADIUS server and the RADIUS secret. For enhanced security, the GbE2 Interconnect Switch permits modification of the RADIUS application port, user-configurable RADIUS server retry and time-out values, and support for SecurID if the RADIUS server can perform an ACE/server client proxy. Both a primary and a secondary RADIUS server may be configured.

The industry-standard RADIUS protocol is an alternative to Cisco's proprietary Terminal Access Controller Access Control System Plus (TACACS+) method. Unfortunately, RADIUS and TACACS+ are not compatible. TACACS+ interoperability is planned for a future GbE2 Interconnect Switch firmware upgrade.

Management

The operating system (OS) of the GbE2 Interconnect Switch provides multiple industry-standard methods to easily configure and manage the GbE2 Interconnect Switch. As with many Catalyst switches, the GbE2 Interconnect Switch provides the ability to store in memory redundant OS images and configuration files. The GbE2 Interconnect Switch may be managed and configured via:

1. Command Line Interface (CLI)
2. Browser based interface (BBI)
3. Simple Network Management Protocol (SNMP)

The GbE2 Interconnect Switch CLI consists of a hierarchal menu/command-based hybrid interface that has a Linux/Unix type look and feel. The hybrid approach permits new users to see available parameters for each command and walks them through command parameters one-by-one. It also allows advanced users to perform command stacking and abbreviations similar to Cisco devices. Industry-standard scripting capabilities are supported for simplified configuration management and switch deployment.

The web console or BBI can be utilized via Internet Explorer or Netscape Navigator over a TCP/IP network. Thus, access is possible throughout the Cisco-based network. Like the CLI, the BBI provides the ability to view and alter GbE2 Interconnect Switch information and settings.

The GbE2 Interconnect Switch supports industry-standard SNMP management information bases (MIBs), HP enterprise switch MIBs, and environmental traps. The SNMP agents are preinstalled in the interconnect switch firmware. Redundant community strings and SNMP trap manager hosts can be configured per switch. This capability allows the interconnect switch to be monitored remotely from an SNMP network management station such as [HP Systems Insight Manager](http://h18000.www1.hp.com/products/servers/management/hpsim/index.html)⁷ and [HP OpenView](http://www.hp.com/products1/softwareproducts/software/openview/index.html)⁸. Additionally, any SNMP-based manager within CiscoWorks or other third party offering may also be used provided it can read industry-standard MIBs and process industry-standard traps.

⁷ Available at <http://h18000.www1.hp.com/products/servers/management/hpsim/index.html>.

⁸ Available at <http://www.hp.com/products1/softwareproducts/software/openview/index.html>.

The GbE2 Interconnect Switch provides other familiar management capabilities consistent with Catalyst switches. These include a local console port with XModem support, access through Telnet and secure shell (SSH), and deployment, back-up, and restore capabilities using trivial file transfer protocol (TFTP) and secure copy protocol (SCP).

Port mirroring

The GbE2 Interconnect Switch port mirroring feature provides the ability send a copy of any network traffic that enters or leaves the switch to a designated (monitor) port for examination by a network analyzer. Traffic ingressing the port, egressing the port, or both may be monitored. The GbE2 port mirroring provides similar functionality as the switched port analyzer (SPAN) feature on Catalyst switches. The GbE2 Interconnect Switch also interoperates with the Cisco Remote SPAN (RSPAN) feature. By targeting mirrored GbE2 data to a port connected to a Catalyst switch utilizing RSPAN, the traffic can be captured for analysis on the designated Catalyst monitoring port.

Multicast traffic

Multicasting reduces network traffic and congestion. The GbE2 Interconnect Switch has the ability to pass IP multicast traffic that is forwarded to it from Catalyst switches. Support for actively participating within internet group management protocol (IGMP) multicasting is not provided on the GbE2 Interconnect Switch at this time, but this support is planned for a future release. Meanwhile, provided the VLANs between the GbE2 Interconnect and Catalyst switches are correctly configured, the GbE2 Interconnect Switch will automatically forward IP multicast traffic out all ports on the VLAN from which the multicast traffic was received.

Network time

The industry standard network time protocol (NTP) synchronizes timekeeping among a set of distributed network devices and time servers. This synchronization allows events to be correlated when system logs are created and other time-specific events occur. As with Catalyst switches, the GbE2 Interconnect Switch provides NTP support. On the GbE2 Interconnect Switch, users can specify the NTP server IP address, update interval, and time zone, and then the Cisco and GbE2 switches are synchronized to the same network time. The GbE2 Interconnect Switch includes a battery-backed real time clock that will maintain the time in the event the NTP server is unavailable.

Conclusion

With the introduction of industry-standard blade servers, the number of Ethernet connections and cables within a rack can quickly become overwhelming. To consolidate these cables, blade manufacturers introduced the concept of integrated Ethernet switches. For network administrators to successfully deploy these new blade switches within their existing networks, interoperability with existing devices and compliance to network industry standards is a must.

Available as one of the several interconnect options for ProLiant BL p-Class systems, the GbE2 Interconnect Switch is ideal for reducing Ethernet network cabling and the time required to deploy, manage, and service ProLiant BL p-Class systems. Its advanced feature support and compliance to IEEE and other Ethernet protocols permits interoperability with networks based on Cisco Catalyst switches and devices from other common vendors found in today's datacenter.

For more information

For additional information, refer to the resources detailed below.

Resource description	Web address
ProLiant BL p-Class system home page	http://h18004.www1.hp.com/products/servers/proliant-bl/p-class/index.html
ProLiant BL p-Class GbE2 Interconnect Switch home page	http://h18004.www1.hp.com/products/servers/proliant-bl/p-class/bl-p-interconnect-switch2.html
<i>ProLiant BL p-Class Networking Overview</i> white paper	http://h18004.www1.hp.com/products/servers/proliant-bl/p-class/bl-p-interconnect-switch2.html
<i>ProLiant BL p-Class GbE2 Interconnect Switch Overview</i> white paper	http://h18004.www1.hp.com/products/servers/proliant-bl/p-class/bl-p-interconnect-switch2.html
<i>Deploying the ProLiant BL p-Class GbE2 Interconnect Switch into a Cisco-based Network</i>	http://h18004.www1.hp.com/products/servers/proliant-bl/p-class/bl-p-interconnect-switch2.html
ProLiant BL p-Class GbE2 Interconnect Switch user guides	http://h18004.www1.hp.com/products/servers/proliant-bl/p-class/bl-p-interconnect-switch2.html

© 2004 Hewlett-Packard Development Company, L.P. The information contained herein is subject to change without notice. The only warranties for HP products and services are set forth in the express warranty statements accompanying such products and services. Nothing herein should be construed as constituting an additional warranty. HP shall not be liable for technical or editorial errors or omissions contained herein.

Catalyst, Cisco, Cisco Systems, and EtherChannel are registered trademarks of Cisco Systems, Inc. All other trademarks or registered trademarks mentioned in this document are the property of their respective owners.

5982-5037EN, 05/2004

